

SLK-Class (from 2008)



Overview of model changes

1. Front

The 'bonnet bulge' and grille design create a tapered and prominent front end, mimicking the front-end shape of an F1 car, underlining the SLK's sporty and dynamic abilities. The front bumper with its central triangular design feature makes the Mercedes-Benz star above even more prominent and adds an aggressive element. The chrome ringed front fog lamps of the SLK also help to create a more sporty look.

2. Side

The SLK now has larger exterior mirrors helping to increase visibility and safety. Although they have a large mirror surface they still have an aerodynamic shape which is in perfect harmony with the car's lines and also reduces dirt build-up on their surface. They also feature the new "arrow" design LED indicator lights that help to increase the visibility of the SLK.

3. Rear

The new generation SLK features a trapezoidal tailpipe design, replacing the oval design of the previous model. The tailpipes are recessed into the smooth rear bumper, helping to create a dynamic rear profile. The rear bumper incorporates a diffuser-look design, helping to enhance the dynamic rear profile of the SLK. Tinted rear light clusters are now across the range, a feature that was previously only found on AMG models. The spoiler lip on the boot lid creates a striking line and is also aerodynamically efficient.

4. Engines

Both the SLK 200 and SLK 350 engines have been updated compared with the previous generation. The SLK 200 power is increased from 163 hp to 184 hp and the SLK 350 is increased from 272 hp to 305 hp.

5. Direct Steering

This system replaces the previous parameter 'speed sensitive' steering option found on cars prior to the 2008 Model Year. Direct Steering assesses the driver's steering input and adapts the steering response accordingly. This improves the car's responsiveness and offers greater assistance when parking or performing other manoeuvres.

6. Wheels

The SLK is available with a range of alloy wheel designs. Significantly, due to the fact that most SLK 200 customers were previously upgrading their wheels to the SLK 280 design, the latest SLK 200 comes with the upgraded 16" wheels as standard.

Technical Data

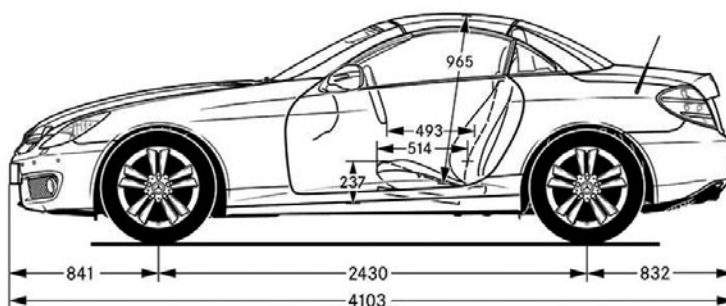
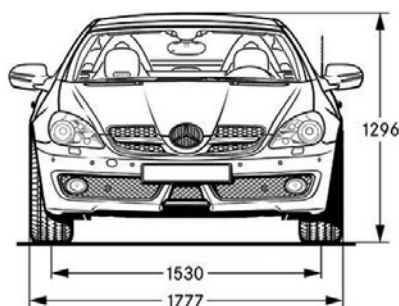

SLK-Class Equipment

Standard features - selection

- Alarm system with immobiliser and interior protection (MBSS3)
- Alloy wheels (4) 16" 5-spoke (SLK 200K / SLK 280)
17" 5-twin-spoke (SLK 350)
- Anti-lock Braking System (ABS) with Brake Assist (BAS)
- Air conditioning
- Cruise control and Speedtronic variable speed limiter
- Electronic Stability Programme (ESP®) with Acceleration Skid Control (ASR)
- Electric-hydraulic vario roof operated via infrared key
- Headlamp Assist (automatic headlamp activation)
- Mercedes-Benz Audio 20 radio / CD with nine speakers
- Multi-function leather trimmed steering wheel with trip computer
- Remote central locking
- Roll-over protection
- Seat belt pre-tensioners and force limiters
- Service indicator (ASSYST)
- Sport seats (electrically adjustable with memory)
- Two stage front airbags and head / thorax sidebags for the driver and passenger
- Wind deflector (fabric)

Options - selection

- Aircarf - neck level heating (with heated seats and leather)
- AMG bodystyling (standard on SLK 55 AMG)
- Bi-Xenon headlamps (standard on SLK 55 AMG)
- COMAND - Cockpit Management and Navigation Display
- Headlamp wash (standard with Bi-Xenon headlamps)
- Heated seats (standard on SLK 55 AMG)
- Leather seating (AMG nappa leather standard on SLK 55 AMG)
- Luxury automatic climate control
- Mirror package: auto dimming rear view mirror and driver's exterior mirror
- Metallic paint (standard on SLK 55 AMG)
- Parktronic - audible and visual parking aid
- Rain-sensing wipers
- Six-disc CD changer with MP3 compatibility
- Tyre pressure loss warning system

SLK-Class Engines (with automatic transmission)

	Cylinders	cc	hp / rpm	Nm / rpm	Cmbd mpg	CO2g/km
SLK 200 Kompressor	4	1,796	184 / 5,500	250 / 2,800-5,000	34.9	192
SLK 280	V6	2,996	231 / 6,000	300 / 2,500-5,000	31	216
SLK 350	V6	3,498	305 / 6,500	360 / 4,900	30.7	219
SLK 55 AMG	V8	5,439	360 / 5,750	510 / 4,000	23.5	288

Transmissions

6-speed Direct Control manual transmission	standard on SLK 200 Kompressor, SLK 280 and SLK 350
5-speed automatic transmission with Tipfunction	optional on SLK 200 Kompressor
7G-Tronic 7-speed automatic transmission with Tipfunction	standard on SLK 55 AMG and optional on SLK 280 and SLK 350